



GISBORNE

DISTRICT COUNCIL

Gisborne District Water Supply Bylaw 2008

CONTENTS

| | | |
|-----------|--|-----------|
| 1. | Introduction | 5 |
| 1.1 | Title | 5 |
| 1.2 | Commencement And Application | 5 |
| 1.3 | Repeals | 5 |
| 1.4 | Scope..... | 5 |
| 1.5 | List Of Schedules Passed In Terms Of Part 5..... | 5 |
| 1.6 | Adoption, Amendment And Revocation Of Schedules | 5 |
| 1.7 | Definitions And Interpretation | 6 |
| 2. | Protection Of Water Supply | 9 |
| 2.1 | Water Supply System..... | 9 |
| 2.1.1 | Access To The Catchment Areas Of The Water Supply System | 9 |
| 2.1.2 | Access To The Water Treatment And Storage Facilities Of The Water Supply System..... | 9 |
| 2.1.3 | Access To The Water Distribution Network Of The Water Supply System | 10 |
| 2.1.4 | Fire | 10 |
| 2.1.5 | Other Uses | 10 |
| 2.1.6 | No Person To Connect To Or Interfere With A Water Supply System | 10 |
| 2.1.7 | Working Around Buried Services..... | 10 |
| 2.2 | Protection Of Source Water | 11 |
| 2.2.1 | Catchment Classes | 11 |
| 2.2.2 | Controlled Catchments | 11 |
| 2.2.3 | Open Catchments..... | 13 |
| 2.2.4 | Application Of Other Bylaws..... | 13 |
| 3. | Conditions Of Supply | 13 |
| 3.1 | Application For Supply | 13 |
| 3.1.1 | Initial Application..... | 13 |
| 3.1.2 | Change Of Use..... | 14 |
| 3.1.3 | Connection To The Water Main..... | 14 |
| 3.2 | Point Of Supply..... | 14 |
| 3.2.1 | Single Ownership | 14 |
| 3.2.2 | Multiple Ownership..... | 14 |
| 3.3 | Access To And About Point Of Supply | 15 |
| 3.3.1 | Rights Of Access | 15 |
| 3.3.2 | Maintenance Of Access..... | 15 |
| 3.4 | Types Of Supply..... | 15 |
| 3.4.1 | On Demand Supply | 15 |
| 3.4.1.1 | Ordinary Supplies | 16 |
| 3.4.1.2 | Extraordinary Supplies | 16 |
| 3.4.2 | Restricted Flow Supply/ Supplementary Supply..... | 16 |
| 3.4.3 | Metering..... | 17 |
| 3.5 | Level Of Service | 17 |
| 3.6 | Continuity Of Supply | 17 |
| 3.6.1 | Supply..... | 17 |

| | | |
|-----------|---|-----------|
| 3.6.2 | Uninterrupted Service | 17 |
| 3.6.3 | Demand Management..... | 18 |
| 3.6.4 | Emergency Restrictions..... | 18 |
| 3.6.5 | Scheduled Maintenance And Repair | 18 |
| 3.7 | Liability | 18 |
| 3.8 | Fire Protection Connection | 18 |
| 3.8.1 | Connection Application | 18 |
| 3.8.2 | Design..... | 19 |
| 3.8.3 | Fire Protection Connection Metering..... | 19 |
| 3.8.4 | Fire Hose Reels | 19 |
| 3.8.5 | Charges..... | 19 |
| 3.9 | Backflow Prevention | 20 |
| 3.10 | Council Equipment And Inspection..... | 20 |
| 3.10.1 | Care Of Water Supply System | 20 |
| 3.10.2 | Inspection..... | 20 |
| 3.11 | Meters And Flow Restrictors | 20 |
| 3.11.1 | Installation | 20 |
| 3.11.2 | Location..... | 21 |
| 3.11.3 | Accuracy | 21 |
| 3.11.4 | Adjustment..... | 21 |
| 3.11.5 | Estimating Consumption | 21 |
| 3.11.6 | Incorrect Accounts..... | 22 |
| 3.11.7 | Plumbing System | 22 |
| 3.11.8 | Prevention Of Waste..... | 23 |
| 3.11.9 | Payment..... | 23 |
| 3.11.10 | Transfer Of Rights And Responsibilities | 23 |
| 3.11.11 | Change Of Ownership..... | 24 |
| 3.11.12 | Disconnection At The Customer's Request | 24 |
| 4. | Miscellaneous Provisions | 24 |
| 4.1 | Breaches Of Conditions Of Supply..... | 24 |
| 4.2 | Offences And Breaches Of The Bylaw..... | 25 |
| 4.3 | Interference With Equipment..... | 27 |
| 4.4 | Penalties For Breach Of The Bylaw..... | 27 |
| 4.5 | Removal Of Works | 27 |
| 4.6 | Transfer Of Approval Or Permit..... | 28 |
| 4.7 | Serving Of Orders And Notices | 28 |
| 4.8 | Officers to Continue In Office | 29 |
| 4.9 | Delegation and Appeal | 29 |
| 4.10 | Dispensing Power..... | 30 |
| 4.11 | Forms | 30 |

1. Introduction

1.1 Title

This Bylaw may be cited as the “Gisborne District Council Water Supply Bylaw 2008”.

1.2 Commencement and Application

This Bylaw shall come into force on the ____ of _____ 2008 and shall apply to the whole of the Gisborne District.

1.3 Repeals

The following Bylaws are hereby repealed:

Gisborne City Council Water Supply and Protection of Water Supply Bylaw 1984.

1.4 Scope

This Bylaw is made under the authority of the Local Government Act 2002 for the supply of water to its Customers by the Council. The supply and sale of water by the Council is subject to:

- (a) Statutory Acts and Regulations:
 - (i) Building Act 2004 and Regulations;
 - (ii) Building Regulations 1992 (including the New Zealand Building Code);
 - (iii) Fire Service Act 1975;
 - (iv) Health Act 1956 and regulations;
 - (v) Local Government Act 1974;
 - (vi) Local Government Act 2002;
 - (vii) Local Government (Rating) Act 2002;
 - (viii) Plumbers, Gasfitters and Drainlayers Act 1976;
 - (ix) Plumbers, Gasfitters and Drainlayers Act 2006;
 - (x) Resource Management Act 1991;
 - (xi) Water Supplies Protection Regulations 1961; *and*
 - (xii) Other applicable enactments;
- (b) Bylaws:
 - (i) Gisborne District Public Places Bylaw 2008;
 - (ii) Gisborne District Reserves Bylaw 2008;

1.5 List Of Schedules Passed In Terms Of Part 5

Schedule 1: Examples of Point of Supply location for Figure 1;
Schedule 2: Examples of Point of Supply location for Figure 2;
Schedule 3: Applicable Codes and Standards;
Schedule 4: Controlled Catchment Areas;

1.6 Adoption, Amendment And Revocation Of Schedules

The Council may from time to time make, amend or revoke the Schedules of this Bylaw listed in clause 1.5 by resolution Publicly Notified pursuant to section 151 of the Local Government Act 2002.

1.7. DEFINITIONS And INTERPRETATION

1.7.1

For the purposes of this Part the following definitions shall apply:

ACT means the Local Government Act 2002;

ADEQUATE SUPPLY means the same as in section 69G of the Health (Drinking Water) Amendment Act;

AIR GAP SEPARATION means a minimum vertical air gap between the outlet of the water supply fitting which fills a Storage Tank, and the highest overflow water level of that Storage Tank;

APPROVAL means Approval by the Council or any Authorised Officer so authorised on behalf of the Council and any Approval may include conditions; **APPROVED** shall have a similar meaning.

AUTHORISED OFFICER means any Person delegated, appointed or authorised in writing by the Council to act on its behalf and with its authority;

COUNCIL means the Gisborne District Council or any Committee of the Council or officer delegated to exercise the authority of the Council;

BACKFLOW means a flow of water or other liquid through any Service Pipe or Supply Pipe in a reverse direction to the normal supply flow;

CUSTOMER means a Person who uses, or has obtained the right to use or direct the manner of use of water supplied by the Council to any Premises;

CONDITIONS OF SUPPLY means the terms and conditions determined by the Council in accordance with section 3 of this Part of the Bylaw;

DETECTOR CHECK VALVE means a check (non-return) valve which has a positive closing pressure and a metered bypass to measure flows typically associated with leakage or unauthorised use on a dedicated fire supply;

DISTRICT means the territory of the Council;

EXTRAORDINARY SUPPLY means a category of 'On Demand Supply' and includes all purposes for which water is supplied other than Ordinary Supply and may be subject to specific conditions and limitations, including Restricted Flow Supply;

FEES AND CHARGES means the list of items, terms and prices for services associated with the supply of water as adopted by the Council in accordance with section 150 and 151 of the Local Government Act 2002;

FIREFIGHTER means an appropriately trained Person assessing the Water Supply Systems for fire fighting capability, and accessing them for the purpose of fighting a fire;

INFRINGEMENT means an offence as specified by this Bylaw under Section 243 and 259 of the Act;

LEVEL OF SERVICE means the measurable performance standards on which the Council undertakes to supply water to its Customers;

ON DEMAND SUPPLY means a supply which is available on demand directly from the Point of Supply subject to the agreed Level of Service;

ORDINARY SUPPLY means a category of On Demand Supply and is the supply of water to a Customer which is used solely for domestic purposes;

PERSON includes a corporation and also a body of Persons whether corporate or unincorporate;

POINT OF SUPPLY to an individual Customer is the point on the service connection which marks the boundary of responsibility between the Customer and the Council, irrespective of property boundaries;

POTABLE means the same as in section 69G of the Health (Drinking Water) Amendment Act;

PREMISES include the following:

- (a) A property or allotment which is held under a separate certificate of title or for which a separate certificate of title may be issued; or
- (b) A building that has been defined as an individual unit by a cross-lease, unit title or company lease and for which a certificate of title is available; or
- (c) Buildings and dwelling houses to which a separate supply of water is provided;
- (d) Land held in public ownership (e.g. reserve) for a particular purpose;

PUBLIC NOTICE means the same as in the Act and 'published' and 'Publicly Notified' have corresponding meanings. A Public Notice setting forth the object, purport, or general effect of a document shall in any case be sufficient notice of that document;

RESTRICTED FLOW SUPPLY or **SUPPLEMENTARY SUPPLY** means where a small continuous flow is supplied by a flow control device, and storage is provided by the Customer to cater for the Customer's demand fluctuations.

RESTRICTOR means a control device fitted to the Service Pipe to regulate the flow of water to a Customer's Premises.

ROADING AUTHORITY means either the Council or Transit New Zealand.

RURAL WATER SUPPLY AREA means an area formally designated by the Council as an area serviced by a reticulated Water Supply System that is intended to supply water for specified purposes via restricted flow supplies and/or on demand supplies but not necessarily with a fire fighting capability;

SERVICE PIPE or **SERVICE LINE** means that section of water pipe between a watermain and the Point of Supply, and owned and maintained by the Council;

SERVICE VALVE or **TOBY** means the valve at the end of the Service Pipe;

STOCK means the same as in Section 2 of the Impounding Act 1955.

STORAGE TANK means any tank having a free water surface used for the storage of Potable water;

SUPPLY PIPE means that section of pipe between the Point of Supply and the Customer's Premises through which water is conveyed to the Premises, and owned and maintained by the Customer;

TARGETED RATES means the same as in section 2 of the Local Government (Rating) Act 2002;

URBAN WATER SUPPLY AREA means an area formally designated by a Council as an area serviced by a reticulated Water Supply System that is intended to supply water to Customers via on demand supplies with a fire fighting capability;

WATER SUPPLY SYSTEM means:

- (a) the catchment areas that provide the source of the water supply to the District including but not limited to:
 - (i) rivers, streams, lakes, waters, and underground waters, and the rights relating to these; and
 - (ii) land, watershed, and water collection areas; and
- (b) the water treatment and storage facilities owned or controlled by the Council including but not limited to wells, infiltration galleries, intake structures, open raw and treated water

- storage ponds/lakes, falling mains, treatment plants, raw and treated water reservoirs, pump stations and pumps; and
- (c) the water distribution network owned or controlled by the Council including but not limited to the trunk mains, service mains, rider mains, valves, hydrants, Service Pipes, boundary assemblies, meters, Backflow preventers and tobies;

WORKING DAY means the same as in Section 5 of the Act;

1.7.2

Words importing the masculine gender include the feminine gender and the neuter gender.

1.7.3

Words importing the singular number include the plural number, and words importing the plural number include the singular number.

1.7.5

For the purposes of this Bylaw the word "shall" refers to practices that are mandatory for compliance with the Bylaw, while the word "should" refers to practices which are advised or recommended.

1.7.6

The headings to the clauses of this Bylaw shall not affect the construction thereof.

1.7.7

Every Schedule to this Bylaw shall be deemed to form part of the Bylaw provided that any such schedule may be altered from time to time in accordance with clause 1.6 of this Bylaw.

2. Protection of Water Supply

2.1 Water Supply System

2.1.1 Access to the catchment areas of the Water Supply System

Except pursuant to clause 2.2 of this Bylaw no Person other than the Council and its authorised agents shall have access to the catchment areas of the Water Supply System.

2.1.2 Access to the water treatment and storage facilities of the Water Supply System

No Person other than the Council and its authorised agents shall have access to the water treatment and storage facilities of the Water Supply System.

2.1.3 Access to the water distribution network of the Water Supply System

Except to connect to the Point of Supply, subject to clause 3.1, and to operate the Service Valve no Person other than the Council and its authorised agents shall have access to the water distribution network of the Water Supply System.

2.1.4 Fire

The right to gain access to, and draw water from fire hydrants for the purpose of fighting fires shall be restricted to fire fighters.

2.1.5 Other uses

The right to gain access to, and draw water from the water supply for uses other than fire fighting shall be restricted to:

- (a) the Council or its agents;
- (b) permit holders: Those Persons who after having submitted an application to the Council are subsequently Approved to draw water from tanker filling points, and in exceptional circumstances, as Approved by the Council, from fire hydrants. Such permits are valid only so long as the permit holder complies with the conditions endorsed on the permit.

Without prejudice to other remedies available, the Council may seize and impound any equipment used by any Person to gain access to, or draw water from, a fire hydrant, and assess and recover the value of water drawn without the authorisation of the Council.

2.1.6 No Person to connect to or interfere with a Water Supply System

Except as set out in clauses 2.1.1, 2.1.3, 2.1.4 and 2.1.5, no Person shall make any connection to or otherwise interfere with any part of the Water Supply System.

2.1.7 Working around buried services

The following shall apply:

- (a) The Council shall keep permanent records (as-built) of the location of its buried services, where these are known. This information shall be available for inspection, at no cost to the users. Charges may be levied to cover the costs of making copies available.
- (b) Any Person proposing to carry out excavation work shall view the records referred to in clause (a) (as-built information) to establish whether or not Council services are located in the vicinity. In addition to the requirements of this Bylaw, any such Person shall be

subject to the Council's requirements relating to utilities consents and/or road opening notices, which ever may be applicable.

- (c) When excavating and working around buried services due care shall be taken to ensure the services are not damaged, and that bedding and backfill is reinstated in accordance with the appropriate Council specification. Excavation within roadways is also subject to the permit process of the appropriate Roading Authority.
- (d) Any damage which occurs to a Council service shall be reported to the Council immediately. The Person causing the damage shall reimburse the Council with all costs associated with repairing the damaged service, and any other costs the Council incurs as a result of the incident.

2.2 Protection Of Source Water

2.2.1 Catchment classes

Catchment areas from which untreated water is drawn for the purposes of water supply are divided into the following classes:

- (a) Controlled;
- (b) Open.

These may apply to both surface water and/or groundwater catchments.

2.2.2 Controlled catchments

- (a) The Council may from time to time specify by resolution Publicly Notified in Schedule 4 of this Bylaw controlled catchment areas.
- (b) Catchment areas which are designated as controlled, or any area held by the Council as a water reserve, shall not be entered by any Person except those specifically authorised or permitted in writing by the Council. Within such areas no Person shall:
 - (i) Camp;
 - (ii) Take or allow to stray any Stock;
 - (iii) Bath or wash any thing;
 - (iv) Deposit any dirt, rubbish or foul material of any kind;
 - (v) Defecate, unless the Council provides facilities for this purpose.
- (c) Entry permits shall forbid, regulate or control the following activities:
 - (i) Hunting, trapping, shooting, fishing or the keeping of bees;
 - (ii) Lighting or maintaining any fire;

- (iii) Taking any dog;
 - (iv) Damaging or destroying any trees, shrubs, or other existing cover, or interference with any property;
 - (v) Carrying of any firearm or weapon of any kind, any trap or any fishing gear which may be used for the hunting or catching of birds, fish or animals; or
 - (vi) Use of any pesticide or toxic substance for any purpose whatsoever.
- (d) Inspection of permits includes:
- (i) No Person to whom any permit has been issued shall enter any controlled catchment area or land held by the Council as a water reserve without presenting such a permit for inspection by an Authorised Officer and notifying the Authorised Officer of their intention of entering such an area as the case may be.
 - (ii) Every Person on any controlled catchment area or land held by the Council as a water reserve shall upon demand produce any such permit for inspection by an Authorised Officer.
 - (iii) No permit issued shall be capable of being transferred.
 - (iv) The Council may at any time, by notice in writing delivered to the holder, revoke or suspend any such permit for such time as shall be stated in such notice.
- (e) In any controlled catchment area or any land held by the Council as a water reserve:
- (i) No Person whether holding any permit issued under the provisions of this Part of this Bylaw or not (other than a duly authorised officer), shall commit or cause or permit to be committed any act which may interfere with or be likely to interfere with the free and lawful exercise of any rights vested in any other Person in any such area.
 - (ii) Every Person shall upon the request of an Authorised Officer immediately leave the controlled catchment area or land held by the Council as a water reserve, but shall nevertheless be liable also to be prosecuted for the breach of any of the provisions of this Part of this Bylaw, and the failure so to leave shall constitute a further offence.

2.2.3 Open catchments

Catchment areas which are designated as open will not restrict or control activities which may occur. However in the event of a spillage, or other event which has released or is likely to release hazardous substances into the waters of the catchment, the Council shall be advised of the details with due urgency. This requirement shall be in addition to those other notification procedures which are required for other authorities.

2.2.4 Application of other bylaws

The provisions of the Gisborne District Council Reserves Bylaw 2008 shall apply to all catchment classes.

3. Conditions of Supply

3.1 Application For Supply

3.1.1 Initial application

- (a) Every application for a supply of water shall be made in writing on the relevant standard Council form together with the prescribed charges. The applicant shall provide all the details required by the Council.
- (b) On receipt of an application the Council shall, after consideration of the matters in clause 3.5, either:
 - (i) Approve the application and inform the applicant of the type of supply, the size of the connection, any particular conditions applicable, and the general Conditions of Supply (including Level of Service) under which water will be supplied; or
 - (ii) Refuse the application and notify the applicant of the decision giving the reasons for refusal.
- (c) For the agreed Level of Service to the applicant, the Council will determine the sizes of all pipes, fittings and any other equipment, up to the Point of Supply. The Council will supply and install the Service Pipe up to the Point of Supply at the Customer's cost; or may allow the supply and installation of the Service Pipe to be carried out by Approved contractors.
- (d) The applicant must have the authority to act on behalf of the owner of the Premises for which the supply is sought, and shall produce written evidence of this if required.
- (e) An Approved application for supply which has not been actioned within one month of the date of application will lapse unless otherwise Approved. Any refund will be at the discretion of the Council.

3.1.2 Change of use

Where a change in the Level of Service or end use of water supplied to Premises occurs, and/or the supply changes from an ordinary to an extraordinary type as provided for in clause 3.4 or vice versa, a new application for supply shall be required.

3.1.3 Connection to the water main

No Person except the Council, its authorised agents or Approved contractors shall make any connection to a water main, including any trunk main, service main or rider main.

3.2 Point Of Supply

3.2.1 Single ownership

The Point of Supply shall be:

- (a) For individual Customers the Point of Supply shall be located as shown in examples 1,2,3 and 4 of Schedule 1. In exceptional circumstances and at the discretion of the Council other alternatives may be Approved.
- (b) For each individual Customer there shall only be one Point of Supply, unless otherwise Approved.
- (c) The typical layout at a Point of Supply is shown in Schedule 2, Figure 2 of this Part of the Bylaw.
- (d) The Council gives no guarantee as to the serviceability of the valve located on the Service Pipe. Where there is no Customer Toby, or where maintenance is required between the Service Valve and the Customer Toby, the Customer may use the Service Valve to isolate the supply. However the Council reserves the right to charge for maintenance of this valve if damaged by such Customer use.

3.2.2 Multiple ownership

The Point of Supply for the different forms of multiple ownership of Premises and/or land shall be:

- (a) For company share/block scheme (body corporate) as for single ownership.
- (b) For leasehold/tenancy in common scheme (cross lease), strata title, and unit title (body corporate) - each owner shall have an individual supply with the Point of Supply determined by agreement with the Council. In specific cases other arrangements may be acceptable subject to individual Approval.

For a multiple ownership supply which was in existence prior to the coming into effect of the Conditions of Supply, the Point of Supply shall be the arrangement existing at that time,

or as determined by agreement with the Council for an individual case.

3.3 Access To And About Point Of Supply

3.3.1 Rights of access

The following times of access apply:

- (a) Where the Point of Supply is on private property the Customer shall allow the Council access to, and about the Point of Supply between 7.30 am and 6 pm on any day for:
 - (i) Meter reading without notice;
 - (ii) Checking, testing and maintenance work with notice being given whenever possible.
- (b) Outside these hours (e.g. for leak detection) the Council will give notice to the Customer in accordance with section 171 of the Local Government Act 2002;
- (c) Under emergency conditions the Customer shall allow the Council free access to, and about the Point of Supply at any hour in accordance with section 173 of the Local Government Act 2002;
- (d) Where access is not made available for any of the above and a return visit is required by the Council, a rate in accordance with the "Meter reading by appointment" item may be charged.

3.3.2 Maintenance of access

The Customer shall maintain the area in and around the Point of Supply free of soil, growth, or other matter or obstruction which prevents, or is likely to prevent convenient access.

3.4 Types Of Supply

3.4.1 On Demand Supply

- (a) On Demand Supply shall consist of ordinary and Extra Ordinary Supply.
- (b) Water shall be supplied to every Premises that is entitled to an Ordinary Supply of water, subject to:
 - (i) The Premises lying within an Urban Water Supply Area if such an area has been constituted by the Council; and
 - (ii) The exclusion of its use under any restrictions made and Publicly Notified by the Council under clause 3.6.3; and
 - (iii) Payment of the appropriate charges in respect of that property; and
 - (iv) These Conditions of Supply, and

- (v) Any other charges or costs associated with subdivision or development.
- (c) The Council shall be under no obligation to provide an Extraordinary Supply of water, (refer also to the provisions of clauses 3.6 and 3.8.2)

3.4.1.1 Ordinary supplies

For ordinary supplies domestic purposes shall include the use of a hose for:

- (a) Washing down a car, boat etc;
- (b) Garden watering by hand;
- (c) Garden watering by a portable sprinkler (subject to the provisions of clause 3.6.3);
- (d) Ornamental water feature holding 10 m³ or less capacity;

3.4.1.2 Extraordinary supplies

- (a) For extraordinary supplies permitted uses shall include:
 - (i) Domestic – spa, swimming pool or ornamental water feature holding in excess of 10 m³ capacity,
 - (ii) Fixed garden irrigation systems;
 - (iii) Domestic fire sprinkler systems;
 - (iv) Commercial and business;
 - (v) Industrial;
 - (vi) Agricultural;
 - (vii) Horticultural;
 - (viii) Viticulture;
 - (ix) Lifestyle blocks;
 - (x) Fire protection systems;
 - (xi) Outside the urban and Rural Water Supply Areas;
 - (xii) Temporary supply;
 - (xiii) Any other use specified by the Council from time to time by Publicly Notified resolution.

3.4.2 Restricted Flow Supply/ supplementary supply

The following apply:

- (a) Restricted flow or supplementary supply shall be available only to Premises within a designated Rural Water Supply Area, or under special conditions set by the Council;

- (b) The water supply shall be restricted so as to deliver the agreed number of water units supplied at a steady flow rate;
- (c) The Council shall charge for the Restricted Flow Supply by either:
 - (i) The volume passing through a meter; or
 - (ii) The agreed number of water units.
- (d) Restricted flow or supplementary supply shall be available only to Premises that have Storage Tanks capable of containing an adequate supply of water for at least 24 hours.

3.4.3 Metering

- (a) Ordinary (On demand) and restricted flow/supplementary supplies of water within any Urban Water Supply Area shall not normally be metered and the cost of such supply shall be as prescribed in the Local Government (Rating) Act 2002, Part 1, sections 9, 15 to 19 and Part 4, sections 101 to 103.
- (b) Extra ordinary (on demand) supply and supply within any Rural Water Supply Area shall be normally metered and charged for in accordance with clause 3.11.9 of this Bylaw.

3.5 Level Of Service

The Council shall provide water in accordance with the Level of Service contained in its Long Term Council Community Plan. For those periods where the Level of Service allows non-compliance with the specified values, the Council will make every reasonable attempt to achieve the specified values.

3.6 Continuity Of Supply

3.6.1 Supply

- (a) The Council does not guarantee an uninterrupted or constant supply of water, or maintenance of an existing pressure which is in excess of an agreed Level of Service, but shall do its best to meet the continuity of supply levels of clause 3.5, subject to the exemptions contained in clauses 3.6.2 and 3.6.3.
- (b) Where works of a permanent or temporary nature are planned which will affect an existing supply, the Council will consult with all known Customers likely to be substantially affected.

3.6.2 Uninterrupted service

If a Customer has a particular requirement for an uninterrupted Level of Service (flow, pressure or quality), it will be the responsibility of that Customer to provide any necessary storage, back up facilities, or equipment.

3.6.3 Demand management

- (a) The Customer shall comply with any restrictions on the use of water to manage high seasonal or other demands that may be Approved by the Council pursuant to section 151 (2) of the Local Government Act 2002.
- (b) Such restrictions will be Publicly Notified by the Council.
- (c) When such restrictions apply the Council will take all practicable steps to ensure that an adequate supply of drinking water is provided to each Point of Supply.

3.6.4 Emergency restrictions

- (a) During an emergency the Council may restrict or prohibit the use of water for any specified purpose, for any specified period, and for any or all of its Customers.
- (b) Such restrictions shall be Publicly Notified by the Council.
- (c) The Council may enact penalties over and above those contained in the Conditions of Supply to enforce these restrictions.
- (d) The decision to make and lift restrictions, and to enact additional penalties, shall be made by the Council, or where immediate action is required by a duly Authorised Officer.

3.6.5 Scheduled maintenance and repair

- (a) Wherever practical the Council will make every reasonable attempt to notify the Customer of a scheduled maintenance shutdown of the supply before the work commences.
- (b) Where immediate action is required and this is not practical, the Council may shutdown or reconnect the supply without notice.
- (c) Shutdowns shall normally not exceed 8 hours.

3.7 Liability

The Council shall endeavour to meet the Level of Service requirements but it shall not be liable for any loss, damage or inconvenience which the Customer (or any Person using the supply) may sustain as a result of deficiencies in, or interruptions to, the water supply.

3.8 Fire Protection Connection

3.8.1 Connection application

- (a) Except for domestic fire sprinkler systems, any proposed connection for fire protection shall be the subject of a separate application to the Council for Approval

- (b) Any such connection shall be subject to the Conditions of Supply.

3.8.2 Design

It shall be the Customer's responsibility to ascertain and monitor whether the fire protection supply available is adequate for the intended purpose.

3.8.3 Fire protection connection metering

The following shall apply:

- (a) In any case where the supply of water to any Premises is metered the Council may allow the supply of water for the purposes of fire fighting to be made in a manner which by-passes the meter, provided however that the drawing of water will only be permitted in the following circumstances:
 - (i) To systems in which the drawing of water is only possible in connection with the sounding of an automatic fire alarm or the automatic notification of the fire brigade; or
 - (ii) Where a Council Approved Detector Check Valve has been fitted on the meter bypass.
- (b) Where an unmetered connection has been provided to supply water to a fire protection system this shall be used for no other purpose than fire fighting and testing the fire protection system except where the fire protection system is installed in accordance with New Zealand Standard 4157: 2002 Fire Sprinkler Systems for Houses;
- (c) For a fire connection installed prior to the coming into effect of the Conditions of Supply which is so constructed or so located that it is likely or possible that water will be drawn from it or from any part of it by any Person for purposes other than fire fighting, the Council may install on such a connection a water meter suitable for the purpose.

3.8.4 Fire hose reels

In any case where the supply of water to any Premises is metered, fire hose reels shall be connected only to the metered supply, not to a fire protection connection.

3.8.5 Charges

Water used for the purpose of extinguishing fires will be supplied free of charge.

3.9 Backflow Prevention

The following shall apply:

- (a) Notwithstanding clause (b) of clause 3.9 the Council may at the cost of the Customer fit a Backflow prevention device on the Council side of the Point of Supply.
- (b) It is the Customer's responsibility (under the Health Act 1956, and the Building Act 2004) to take all necessary measures on the Customer's side of the Point of Supply to prevent water which has been drawn from the Council's water supply from returning to that supply. These include:
 - (i) Backflow prevention either by providing an adequate air gap, or by the use of a Backflow prevention device;
 - (ii) The prohibition of any direct cross-connection between the Council water supply and
 - (1) Any other water supply (Potable or non-Potable)
 - (2) Any other water source
 - (3) Any Storage Tank
 - (4) Any other pipe, fixture or equipment containing chemicals, liquids, gases, or other non potable substances.

3.10 Council Equipment And Inspection

3.10.1 Care of Water Supply System

The Customer shall take due care not to damage any part of the Water Supply System, including but not limited to pipework, valves, meters, Restrictors, chambers and Backflow prevention devices.

3.10.2 Inspection

The provisions of section 181 of the Local Government Act 2002 shall apply to inspections by the Council to determine if the Customer is in compliance with the Conditions of Supply.

3.11 Meters And Flow Restrictors

3.11.1 Installation

The following shall apply:

- (a) Meters for on demand metered supplies, and Restrictors for restricted flow supplies, shall be supplied installed and maintained by the Council at the cost of the Customer. These devices shall remain the property of the Council.

- (b) For on demand supplies which are not metered, the Council reserves the right, where it considers water use is unusually high, to fit a meter, at the Customers cost, and charge accordingly.

3.11.2 Location

Meters and Restrictors shall be located in a position which is readily accessible for reading and maintenance, and if practicable immediately on the Council side of the Point of Supply, in accordance with the examples in Schedule 2, Figure 2 of this Bylaw.

3.11.3 Accuracy

A Customer who disputes the accuracy of a meter or Restrictor may apply to the Council for it to be tested provided that it is not within 3 months of the last test. If the test shows non-compliance with the accuracy requirement adopted by the Council then the Customer will not be charged for the test. If the test shows compliance then the Customer shall pay a fee in accordance with the Council current Fees and Charges.

3.11.4 Adjustment

- (a) Should any meter, after being tested, be found to register a greater or lesser consumption than the quantity of water actually passed through such a meter the Council shall make an adjustment in accordance with the results shown by such tests backdated for a period at the discretion of the Council but not exceeding 12 months, and the Customer shall pay a greater or lesser amount according to such an adjustment.
- (b) Where a meter is under reading by more than 20 % or stopped, the Council reserves the right to charge for the amount of water assessed as having been used over the past billing period, and taking into account any seasonal variations in demand.
- (c) Where a meter is over reading, the Council shall make appropriate adjustments to the Customer's invoice(s), based on a period of similar use and backdated or when it is agreed the over reading is likely to have occurred.

3.11.5 Estimating consumption

The following shall apply:

- (a) Should any meter be out of repair or cease to register, or be removed, the Council shall estimate the consumption for the period since the previous reading of such meter based on the Council's rates remission policy and the Customer shall pay accordingly. Provided that when by reason of a large variation of

consumption due to seasonal or other causes, the average of the previous 4 billing periods would be an unreasonable estimate of the consumption the Council may take into consideration other evidence for the purpose of arriving at a reasonable estimate, and the Customer shall pay according to such an estimate.

- (b) If metering indicates a significant increase in consumption to a Premises, which is established as being caused by a previously unknown leak, the Council may estimate consumption as provided in the rates remission policy, providing that the Customer repairs the leak with due diligence.
- (c) Where the seal or dial of a meter is broken, the Council may declare the reading void and estimate consumption as provided above. The Council may repair the seal or dial at the cost of the Customer.

3.11.6 Incorrect accounts

The following shall apply:

- (a) Where a situation occurs, other than as provided for in clause 3.10.5, where the recorded consumption does not accurately represent the actual consumption on a property then the account shall be adjusted using the best information available to the Council. Such errors include, but are not limited to, misreading of the meter, errors in data processing, meters assigned to the wrong account, and unauthorised supplies.
- (b) Provided that where an adjustment is required, in favour of the Council or the Customer, this shall not be backdated more than 12 months from the date the error was detected.

3.11.7 Plumbing system

The following shall apply:

- (a) Quick-closing valves, pumps, or any other equipment which may cause pressure surges to be transmitted within the Water Supply System, or compromise the ability of the Council to maintain its stated levels of service, shall not be used on any piping directly connected to the Service Line. In special circumstances such equipment may be Approved by the Council.
- (b) In accordance with the New Zealand Building Regulations the plumbing system shall be compatible with the water supply. Specific features of the Council supply which need to be taken into account are contained in table 1.

Table 1

| Feature | Value (On Demand) at the boundary |
|--|--|
| Maximum pressure | 900 kPa |
| Minimum pressure for 95% of properties | 300 kPa |
| Normal operating pressure | 500 to 600 kPa |

3.11.8 Prevention of waste

The following shall apply:

- (a) The provisions of section 192 and section 224 of the Local Government Act 2002 shall apply to the waste of water.
- (b) The Council provides water for consumptive use not as an energy source. The Customer shall not use water or water pressure directly from the supply for driving lifts, machinery, educators, generators or any other similar device; unless specifically Approved.
- (c) The Customer shall not use water for a single pass cooling system or to dilute trade waste prior to disposal, unless specifically Approved. A single pass cooling system may be used without specific Approval where the water is not wasted but subsequently used for other purposes.

3.11.9 Payment

The following shall apply:

- (a) The Customer shall be liable to pay for the supply of water and related services in accordance with the Council current Fees and Charges which shall be determined in accordance with section 150 of the Local Government Act 2002.
- (b) The Council may recover all unpaid water charges as prescribed in the Local Government (Rating) Act 2002, Part 3, sections 57 and 58, and 59 to 82.

3.11.10 Transfer of rights and responsibilities

The following shall apply:

- (a) The Customer shall not transfer to any other party the rights and responsibilities provided for under the Conditions of Supply.
- (b) A supply line shall serve only one Customer, and shall not extend by hose or any other pipe beyond that Customer's property.
- (c) In particular and not in limitation of the above any water which the Customer draws from the Council

supply shall not be provided to any other party without Approval of the Council.

3.11.11 Change of ownership

- (a) In the event of a premise changing ownership the Council will automatically record the new owner as being the Customer at that Premises.
- (b) Where a premise is metered the outgoing Customer shall give the Council five Working Days notice to arrange a final reading.

3.11.12 Disconnection at the Customer's request

The Customer shall give twenty Working Days notice in writing to the Council of the requirement for disconnection of the supply.

4. Miscellaneous Provisions

4.1 Breaches Of Conditions Of Supply

- (a) The following are deemed breaches of the conditions to supply water:
 - (i) An incorrect application for supply which fundamentally affects the Conditions of Supply;
 - (ii) Failure by the Customer to meet and comply with the Conditions of Supply;
 - (iii) Failure to meet any obligation placed on the Customer under any enactment specified in clause 1.4;
 - (iv) Frustration of the Council's ability to adequately and effectively carry out its obligations;
 - (v) An act or omission including but not limited to:
 - (1) Failure to pay the appropriate charges by the due date;
 - (2) Failing to repair a leak, or in any way wilfully allowing water to run to waste or to be misused;
 - (3) The fitting of quick-closing valves, subject to clause 3.11.7;
 - (4) Failing to prevent Backflow in accordance with clause 3.9;
 - (5) Failing to comply with water use restrictions or prohibitions introduced by the Council for any specified purpose;
 - (6) Using water or water pressure directly from the supply for driving lifts, machinery, educators, generators or any other similar device; unless specifically Approved by the Council;

- (7) Using water for a single pass cooling or heating system without subsequent use of the water, or to dilute trade waste prior to disposal, unless specifically Approved;
 - (8) Extending by hose or any other pipe water supplied to any Premises beyond those Premises;
- (b) In the event of a breach, the Council will serve notice on the Customer advising the nature of the breach and the steps to be taken to remedy it.
 - (c) If the breach is not rectified, the Council may after five Working Days after the notice had been served on the Customer reduce the flow rate in accordance with section 193(1) of the Local Government Act 2002.
 - (d) If the breach is such that the Council is required to disconnect the supply in accordance with section 194 of the Local Government Act 2002, such disconnection will be carried out forthwith.

4.2. Offences And Breaches Of The Bylaw

4.2.1

No Person shall do anything or cause any condition to exist for which prior written Approval from the Council is required under this Bylaw without first obtaining that Approval and the failure to do so shall constitute a breach of this Bylaw.

4.2.2

No application for a prior written Approval from the Council, and no payment of or receipt for any fee paid in connection with such application or Approval, shall confer any right, authority, or immunity on the Person making such application or payment.

4.2.3

Any Person commits a breach of this Bylaw who:

- (a) Does, or causes to be done, or knowingly permits or suffers to be done anything whatsoever contrary to or otherwise than as provided by this Bylaw; or
- (b) Omits or neglects to do, or knowingly permits or suffers to remain undone, anything which according to the true intent and meaning of this Bylaw, ought to be done by them at the time and in the manner therein provided; or
- (c) Does not refrain from doing anything which under this Bylaw they are required to abstain from doing; or
- (d) Knowingly permits or suffers any condition of or things to exist contrary to any provision contained in this Bylaw; or

- (e) Refuses or neglects to comply with any notice duly given to him/her under the Bylaw; or
- (f) Obstructs or hinders any Authorised Officer of Council in the performance of any duty to be discharged by that officer under or in the exercise of any power conferred upon them by this Bylaw; or
- (g) Fails to comply with any notice or direction given under this Bylaw.

4.2.4

Any Person commits a breach of this Bylaw who:

- (a) Having constructed, affixed or provided, or caused to be constructed, affixed, or provided, any work, appliance, or material of any description whatsoever, contrary to, or otherwise than in accordance with the provision of this Bylaw; or
- (b) Having omitted to construct, affix, or provide any work, appliance or materials as required thereby, and who does not within a reasonable time after notice in writing has been given to them by the Council or any Authorised Officer of the Council, fails to carry out the remedial action specified in that notice;

4.2.5

The notice issued under clause 4.2.3 or 4.2.4 shall state the time within which the remedial action is to be carried out, and may be extended from time to time by written authority of an Authorised Officer.

4.2.6

The provisions of clause 4.2.4 shall also apply to any work, appliance, or material that has, before the coming into force of this Bylaw, been constructed, affixed, or provided or omitted contrary to otherwise than as provided by any provision of any Bylaw hereby repealed, but re-enacted, in substance in this Bylaw. Notice as aforesaid may be given and renewed in respect of any such work, appliance or material.

4.2.7

The Council may pursuant to section 175 of the Act recover the amount of the destruction or damage, the cost incurred by the Council in removing the stoppage or obstruction or any loss or expenses incurred by the Council by the stoppage or obstruction or interference by any Person who wilfully or negligently destroys, damages, stops, obstructs, or otherwise interferes with any works or property owned, constructed, acquired, or used by the Council.

4.3 Interference With Equipment

- (a) Any tampering or interfering with Council equipment, either directly or indirectly, shall constitute a breach.
- (b) Without prejudice to its other rights and remedies, the Council shall be entitled to estimate in accordance with section 3.11.5 and charge for the additional water consumption not recorded or allowed to pass where a meter or Restrictor has been tampered with, and recover any costs incurred.

4.4. Penalties For Breach Of The Bylaw

4.4.1

Every Person who fails to comply with any part of this Bylaw commits an offence and shall be subject to the penalty provisions outlined in the offences, penalties, Infringement offences, and legal proceedings provisions of the Local Government Act 2002 and the enabling enactment.

4.4.2

Where any Person is alleged to have committed an Infringement offence, that Person may either:

- (a) Be proceeded against summarily for the offence; or
- (b) Be served with an Infringement notice as provided in the Act or the enabling enactment;

4.4.3

The Council may in accordance with section 162 of the Act apply for an injunction restraining a Person from committing a breach of this Bylaw or an offence against the Act.

4.4.4

The Council may in accordance with section 176 of the Act recover the costs of remedying any damage caused in the course of committing an offence against this Bylaw.

4.4.5

The continued existence of any work or object in a state contrary to this Bylaw shall be deemed a continuing offence within the meaning of this clause.

4.5. Removal Of Works

4.5.1

The Council may pull down, remove or alter or cause to be pulled down, removed or altered any work, material or thing erected or being in contravention of this Bylaw, section 357 of the Local Government Act 1974 or section 163 of the Local Government Act 2002.

4.5.2

The Council may recover from any Person responsible for the erection or from any Person permitting the continued existence of any such work material or object all costs incurred by it, in connection with such pulling down, removal or alteration.

4.5.3

The exercise of this authority shall not relieve any such Person from responsibility for any penalty for erecting or permitting the continued existence of any such work, material or object.

4.6. Transfer Of Approval Or Permit

The Approval given by the Council to a Person named in that Approval shall not be transferable to any other Person and no Approval shall authorise any Person other than the Person named therein to act in any way under its terms or conditions.

4.7. Serving Of Orders And Notices

4.7.1

Except where otherwise provided for in any enactment, in any case in which it is provided by this Bylaw, that notice be given to any Person requiring them to do or abstain from doing anything, or any notice is required by this Bylaw to be given or sent to any Person, such notice shall be delivered to such Person and may be delivered to them either Personally or by sending the same, by courier, post, fax or electronic means, to them at their last-known place of abode or business.

4.7.2

If such Person is absent from New Zealand the order or notice may be sent to their agent instead of to such Person, in the manner mentioned in clause 4.7.1.

4.7.3

If such a Person is not known, or is absent from New Zealand, and has no known agent in New Zealand, and the notice relates to any land or building, the order or notice addressed to the owner or occupier of such building or land, as the case may require, may be served on the Person in occupation thereof, or left with some other resident of the abode; or, if there is no Person in occupation, may be put up on some conspicuous part of such building or land. It shall not be necessary in such notice to name the occupier or the owner of such land or building.

4.7.4

Where an order or notice is sent by post it shall be sent so as to arrive on or before the latest time on which such order or notice is required to be served.

4.7.5

Unless evidence indicates the contrary where an order or notice is sent by:

- (a) post it will be deemed received on the first day (excluding weekends and public holidays) after posting.
- (b) facsimile or email and the sender's facsimile or email machine produces a transmission report indicating that the facsimile or email was sent to the addressee, the report will be prima facie evidence that the facsimile or email was received by the addressee in a legible form at the time indicated on that report.
- (c) courier and the courier obtains a receipt or records delivery on a courier run sheet, the receipt or record of delivery on a courier run sheet will be prima facie evidence that the communication was received by the addressee at the time indicated on the receipt or courier run sheet.

4.8. Officers To Continue In Office

4.8.1

All officers appointed by the Council under or for the purpose of the repealed Gisborne City Council Water Supply and Protection of Water Supply Bylaw 1984, and holding office at the time of the coming into operation of this Bylaw, shall be deemed to have been appointed under this Bylaw.

4.8.2

Any Police Officer may exercise the powers of an enforcement officer in relation to offences against, and infringement offences under this Bylaw pursuant to the Act.

4.9. DELEGATION And APPEAL

4.9.1

In all cases where this Bylaw provides for the issue of any notice or Approval, such notice or Approval shall be deemed to be issued in compliance with this Bylaw if the same is issued by any officer of the Council authorised by the Council for that purpose.

4.9.2

- (a) There shall be a right of appeal by an affected party from any decision by a delegated authority to original holder of the power and duty. Provided that the original holder of the power and duty may, after consultation with the Chief Executive, refer the appeal to the Council when in his opinion this is justified.
- (b) Where the original holder of the delegated power and duty is the Council the right of appeal may be to a committee of the Council or Authorised Officer

appointed for this purpose, who shall be the final arbitrator of the merits of the matter.

4.10. Dispensing Power

4.10.1

Where in the opinion of the Council full compliance with any of the provisions of this Bylaw would needlessly or injuriously affect any Person, or the course or operation of the business of, or be attended with loss or inconvenience to any Person without any corresponding benefit to the community, the Council may, on the special application of that Person, dispense with the full compliance with the provisions of this Bylaw; provided that any other terms or conditions (if any) that Council may deem fit to impose shall be complied with by that Person.

4.10.2

The Council may, after consideration of any representation by affected Persons and if in its opinion it is justified, extend, withdraw or amend the dispensation granted in terms of clause 4.10.1.

4.10.3

Except if expressly granted otherwise, the dispensation by the Council in terms of clause 4.10.1 shall only be applicable to the Person it is granted to and shall be restricted to the particular issue considered by the Council and such dispensation will not constitute a justification for the breach of the provisions of this Bylaw outside the expressed terms of the dispensation.

4.11 FORMS

Wherever throughout this Bylaw forms are prescribed, slight deviations there from, but to the same effect and not calculated to mislead, shall not invalidate them.

THE COMMON SEAL OF GISBORNE DISTRICT COUNCIL WAS HERETO AFFIXED PURSUANT TO RESOLUTION PASSED AT A MEETING OF THE GISBORNE DISTRICT COUNCIL HELD ON _____(DAY) OF _____ (MONTH) 2008.

----- MAYOR

----- CHIEF EXECUTIVE

SCHEDULE 1 OF THE WATER SUPPLY BYLAW

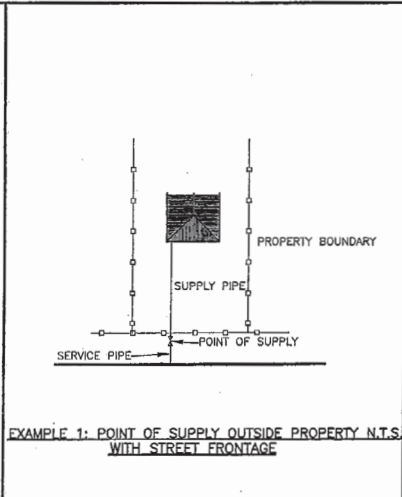
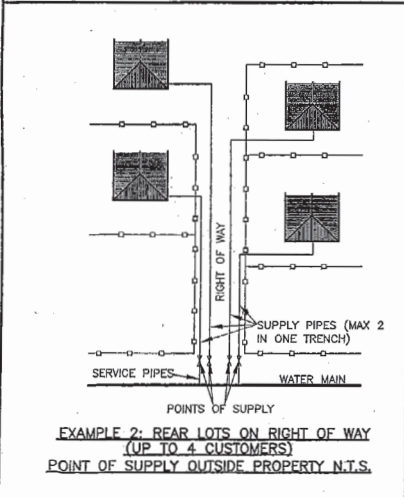
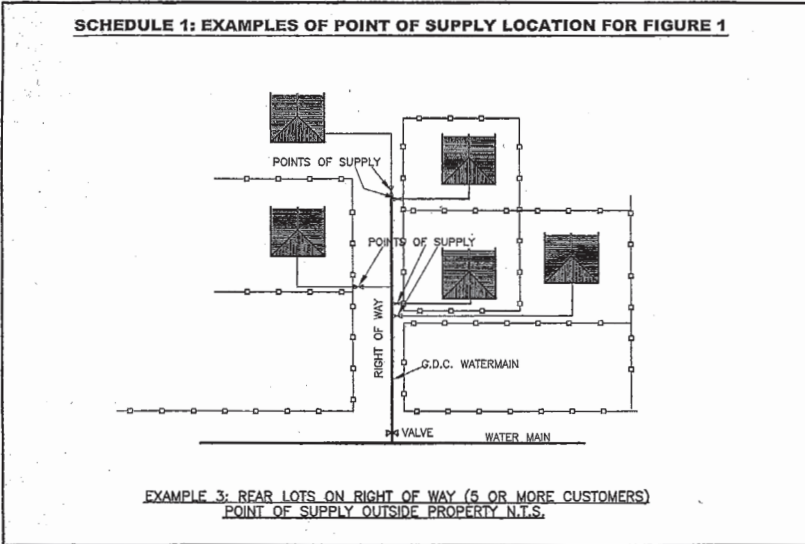

| | | | | | | |
|----------------------------------|--------------|--------|----------------------------------|-------------|-------------|--------------|
| GISBORNE DISTRICT COUNCIL | | | POINT OF SUPPLY LOCATIONS | | | |
| SCALE : N.T.S. | | | TRACED | | PLAN NUMBER | |
| DESIGNED | COMPILED | 8/2007 | CHECKED | K.STRONGMAN | 8/2007 | WR194 |
| DRAWN | D.HEMMINGTON | 8/2007 | APPROVED | | | |

SCHEDULE 2 OF THE WATER SUPPLY BYLAW

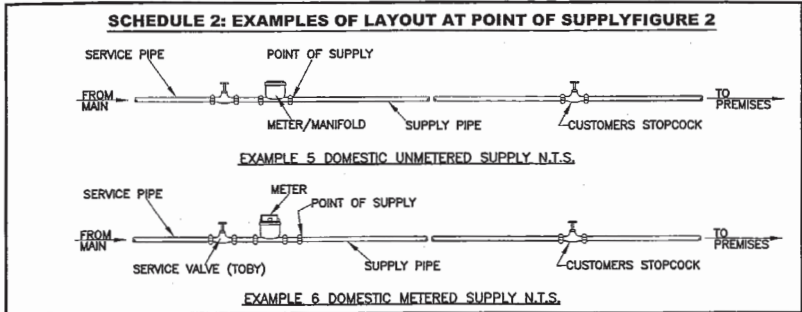

INDUSTRIAL, COMMERCIAL, DOMESTIC FIRE & SERVICE CONNECTIONS (INCL SCHOOLS)

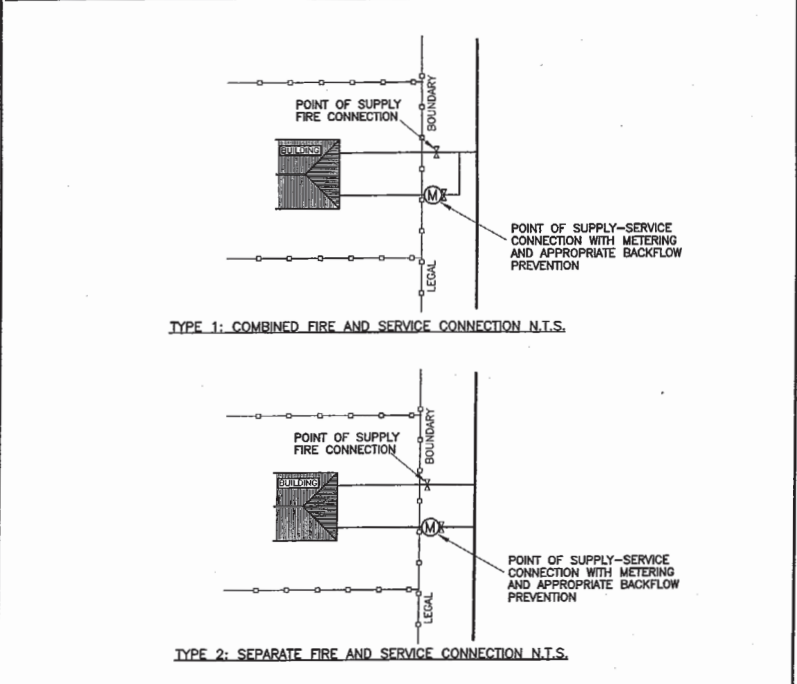

| | | | | | |
|----------------------------------|--------------|--------|----------------------------------|-------------|----------------|
| GISBORNE DISTRICT COUNCIL | | | POINT OF SUPPLY LOCATIONS | | |
| SCALE : N.T.S. | | | TRACED | | PLAN NUMBER |
| DESIGNED | COMPILED | 8/2007 | CHECKED | K.STRONGMAN | 8/2007 |
| DRAWN | D.HEMMINGTON | 8/2007 | APPROVED | | WR194/1 |

SCHEDULE 2 OF THE WATER SUPPLY BYLAW cont'

Schedule 2 (continued)

Example 7 – Metered supply with reduced pressure backflow preventer

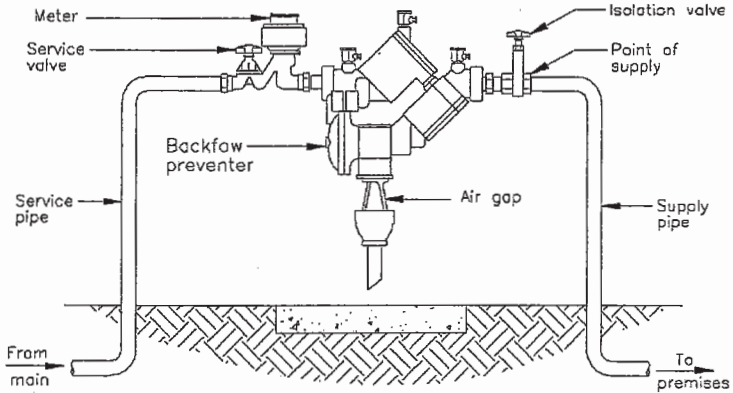

Example 8 – Unmetered supply with vacuum breaker backflow preventer

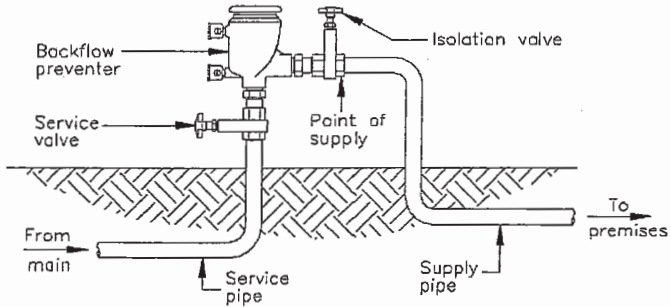

* The building code may require the customer to install additional backflow preventers within the site, which will remain the responsibility of the customer.

SCHEDULE 3 OF THE WATER SUPPLY BYLAW CODES AND STANDARDS

The Council adopts by resolution the following Codes and Standards to apply as a source of reference to activities regulated by the Water Supply Bylaw.

a) **Codes and Standards: Water Supply**

| REFERENCE | CODES AND STANDARDS | DATE CONFIRMED BY COUNCIL | EFFECTIVE DATE | DATE REVOKED |
|--------------------|--|---------------------------|----------------|--------------|
| DWSNZ 2005 | Drinking Water Standards for New Zealand 2005 | | | |
| BS 5728 | BS 5728 <i>Measurement of flow of cold Potable water in closed conduits Part 3:1997 Methods for determining principal characteristics of single mechanical water meters.</i> | | | |
| BS EN 14154-3:2005 | BS EN 14154-3:2005 Water meters. Test methods and equipment. | | | |
| SNZ/PAS 4509:2003 | SNZ/PAS 4509:2003 Fire fighting water supplies Code of Practice | | | |
| Backflow COP | NZWWA Backflow Code of Practice | | | |
| Water Meter COP | NZWWA Water Meter Code of Practice | | | |

SCHEDULE 4 OF THE WATER SUPPLY BYLAW CONTROLLED CATCHMENT AREAS

Pursuant to clause 2.2.2(a) of this Bylaw the Council determines the following areas as being controlled catchment areas:

- (a) Waingake Bush Catchment and Mangapoike Dam Catchment, as indicated on Appendix "A";

